

GROUND CONNECTION:

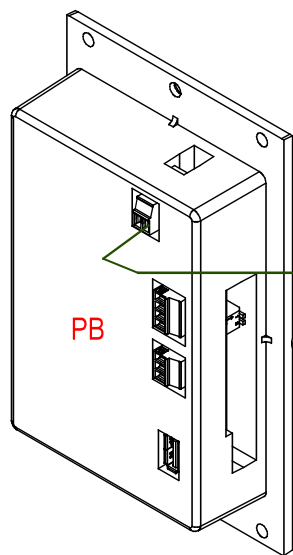

DASHBOARD "L"  
FASTON

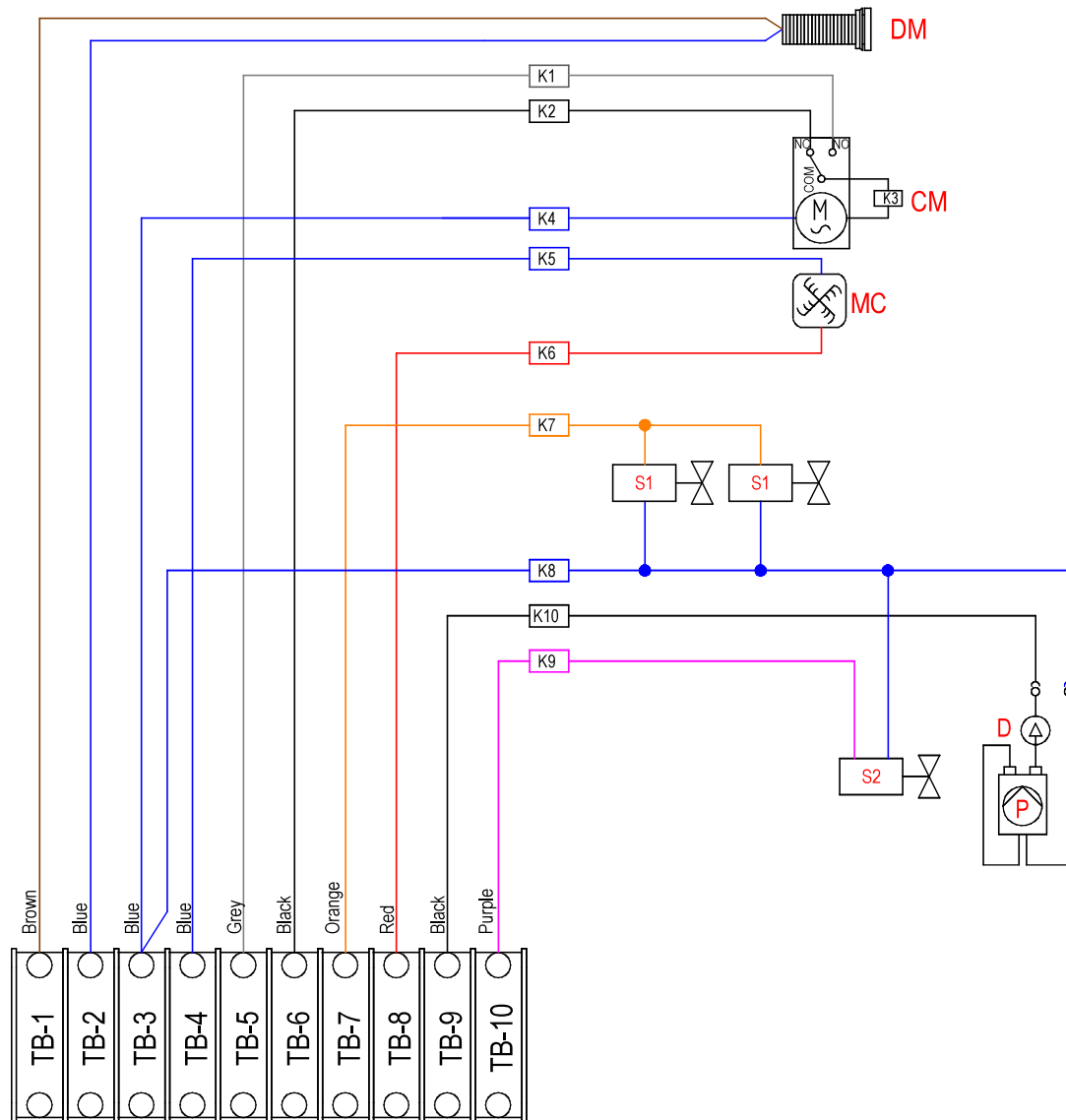
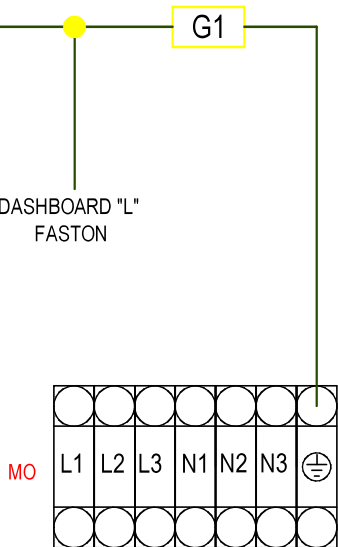

## LEGEND:

CM = Chimney motor

CP = Chamber probe

D = Diode

DB = Display board

DM = Magnet door

EL = Oven light

FU = Fuse

GS = Power supply

M = Motor

MC = Cooling motor

MO = Main terminal block

MS = Wago connector

NP1 = Core probe

P = Detergent pump

PB = Electronic board

S1 = Solenoid valve

S2 = Washing solenoid valve

ST = Safety thermostat

TB = Terminal block

TV = Voltage transformer

K = Contactor