

GROUND CONNECTION:

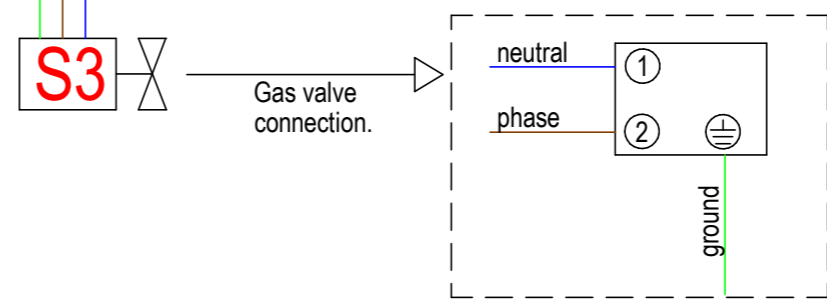
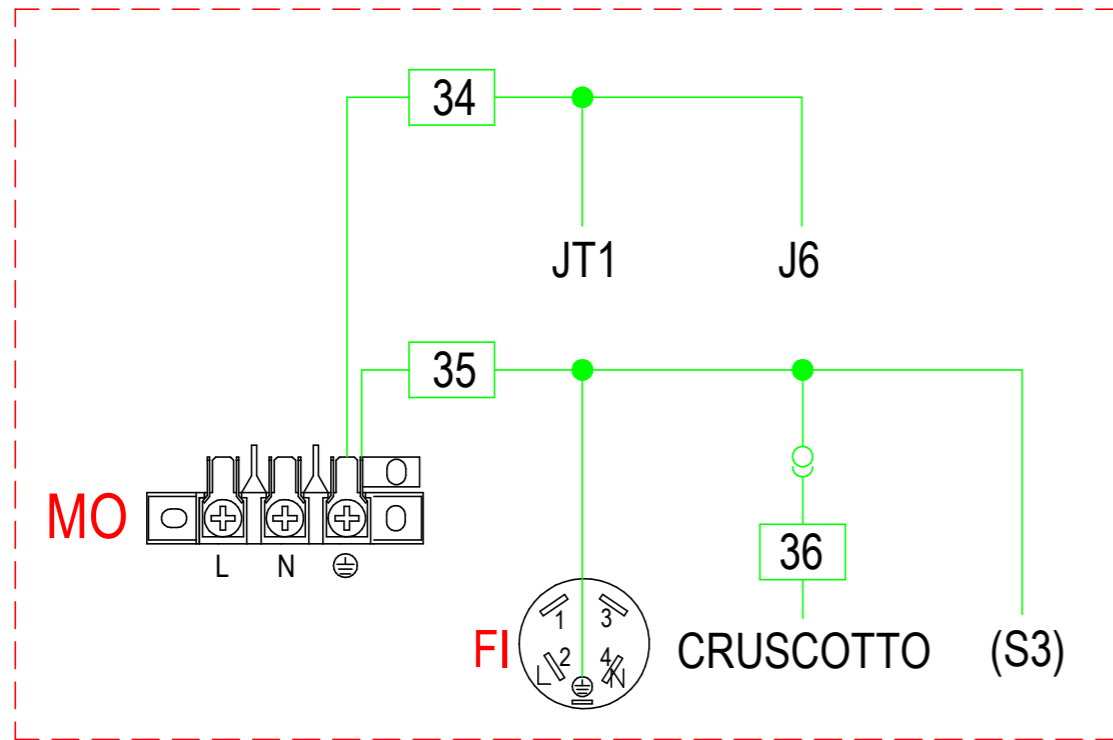

LEGEND:

BB = Burner board

BD = Door button

BR = Reset button

C = Capacitor

CP = Chamber probe

EL = Led

FI = Filter

FU = Fuse

GS = Power supply

HA = Acoustic signal

M = Motor

MC = Cooling motor

MO = Main terminal block

MS = Wago connector

NP1 = Needle probe

PB = Power board

PD = Detergent pump

S1 = Solenoid valve

S2 = Washing solenoid valve

S3 = Gas valve

ST = Safety thermostat

TB = Terminal block

TV = Voltage transformer

K = Contactor