

TB

TB-1	TB-2	TB-3	TB-4	TB-5	TB-6	TB-7	TB-8	TB-9	TB-10
------	------	------	------	------	------	------	------	------	-------

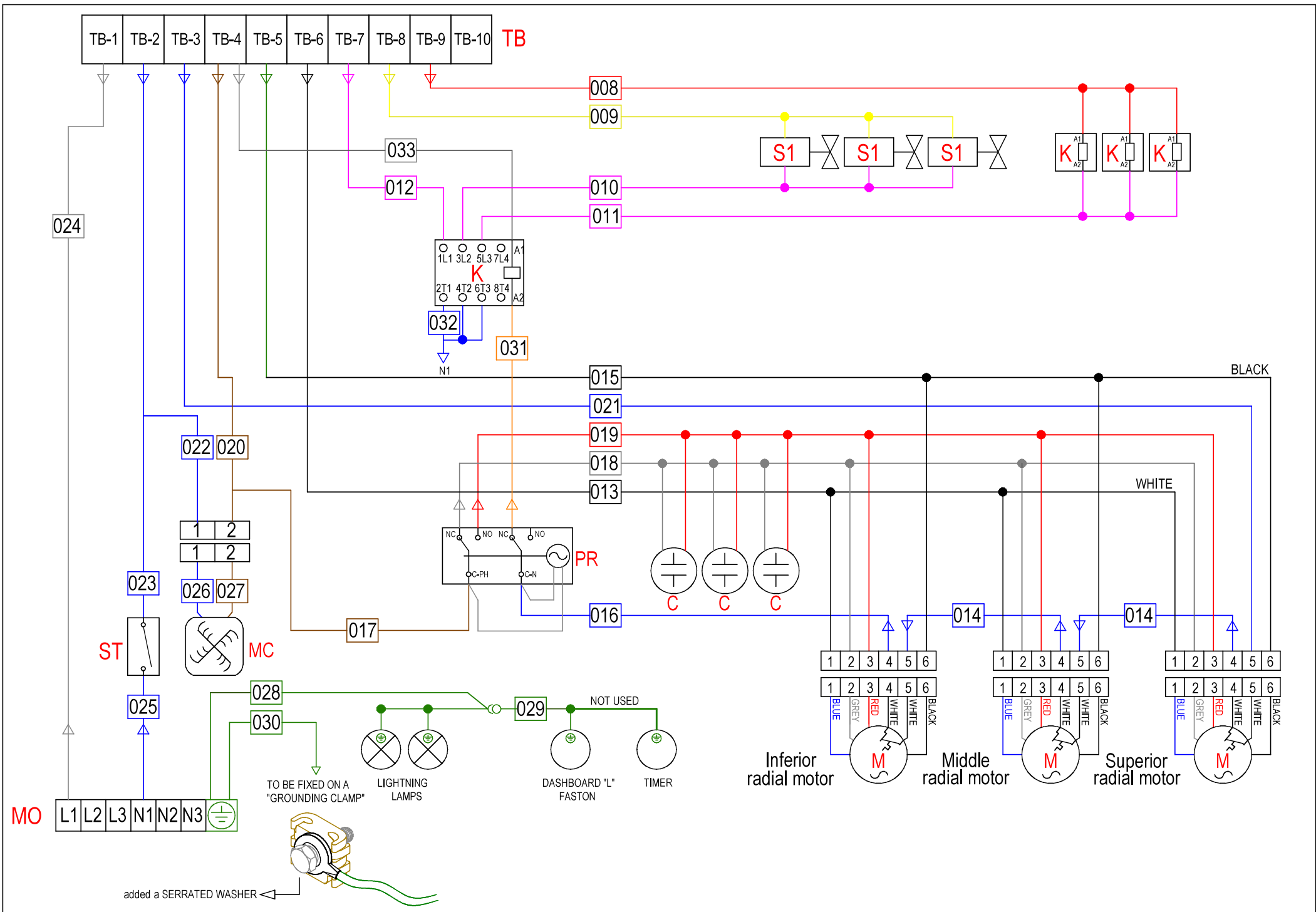

LEGEND:

BD = Door button
BS = Speed button
C = Capacitor
EL = Oven light
HA = Acoustic signal
HL1 = Thermostat signal lamp
HL2 = Humidity signal lamp
HS = Humidity selector
L = Phase
M = Motor

MC = Cooling motor
MO = Main terminal block
N = Neutral
PN1 = Core probe
PR = Cam programmer
S1 = Solenoid valve
ST = Safety thermostat
TH = Thermostat
TI = Timer
K = Contactor