

Electrical Wiring

F.1	Electrical Wiring	
F.2	Spare parts	
	Power board	
	Control board	

code

FE-5306-EE

model

ELECTRIC DECK OVEN

power

ELECTRIC

instrumentation

ELECTRONIC

details

with "DIXELL"

operating voltage	400 Vac
auxiliary voltage	24 Vac
frequency	50-60 Hz

CE

revision

R-0

creation date

17/11/1997

revision date

01/09/2014

design

DF

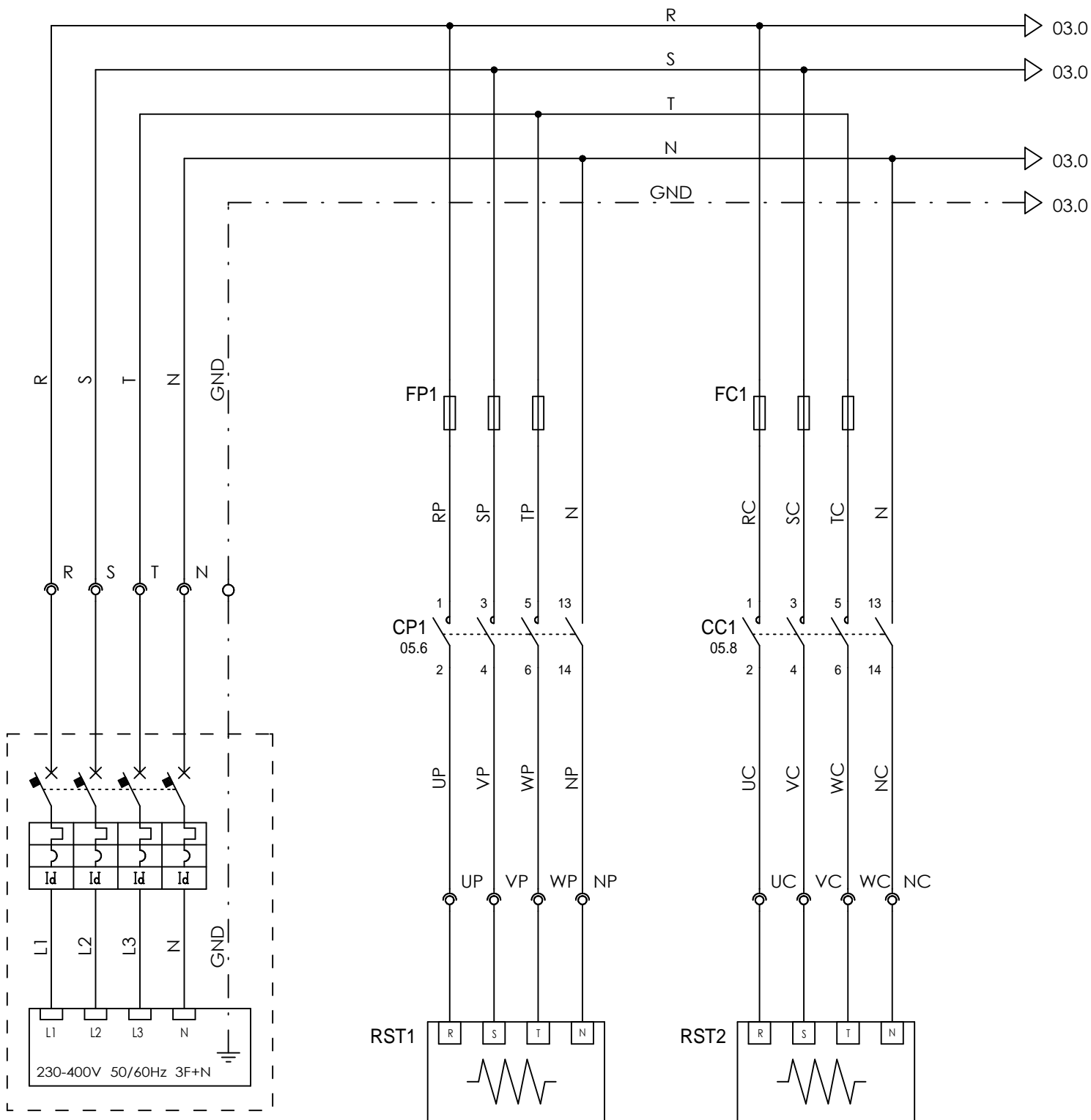

POWER SUPPLIER

BEDPLATE HEATING ELEMENTS

CEILING HEATING ELEMENTS

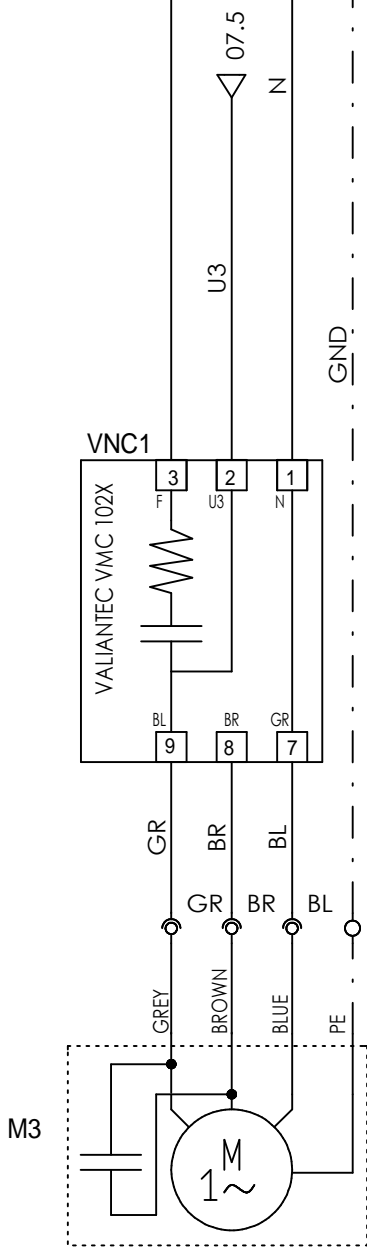
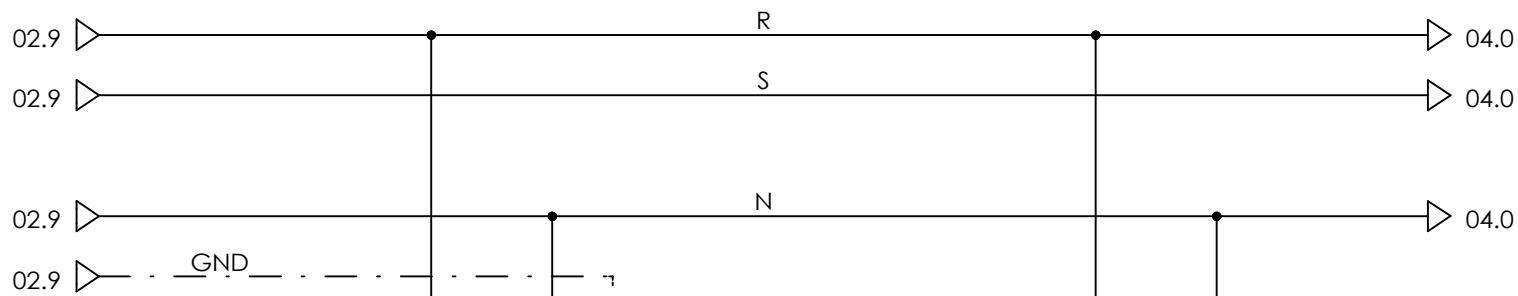

STEAM SUCTION FAN

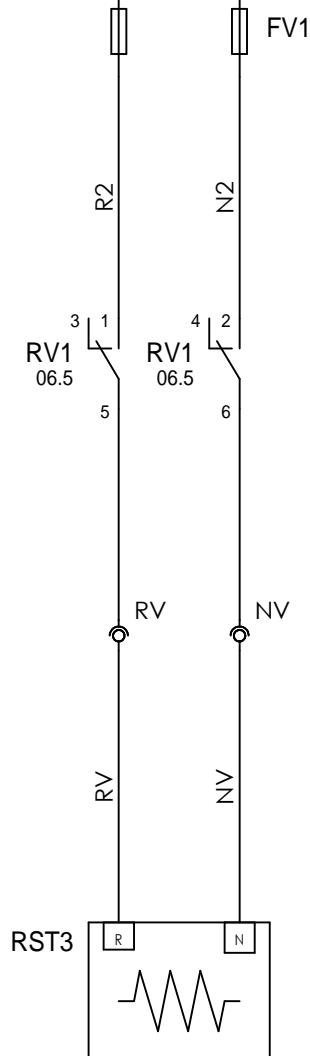

STEAM SET ELEMENT

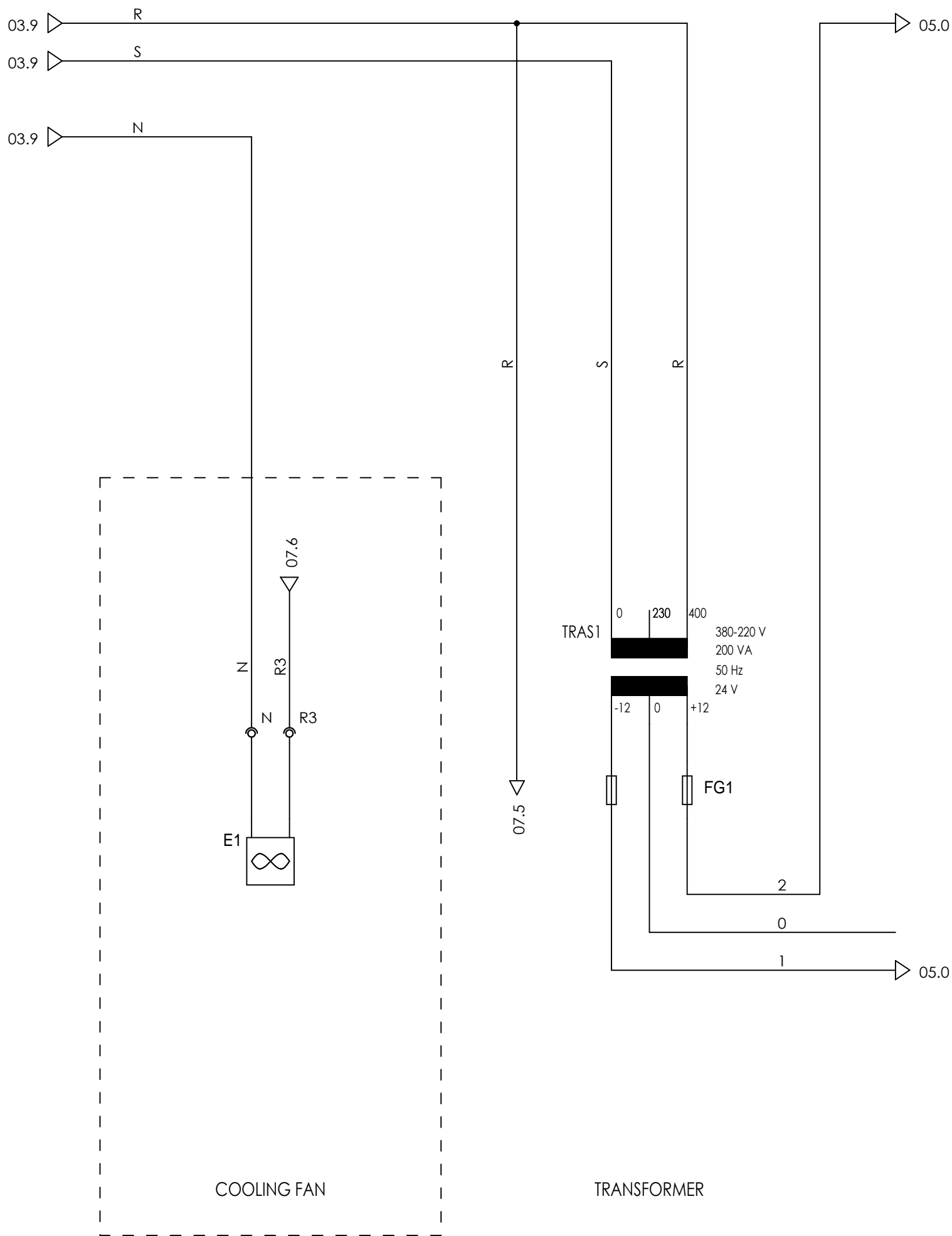

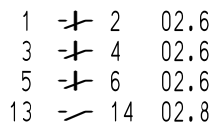
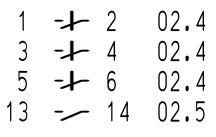
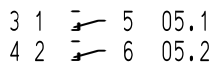
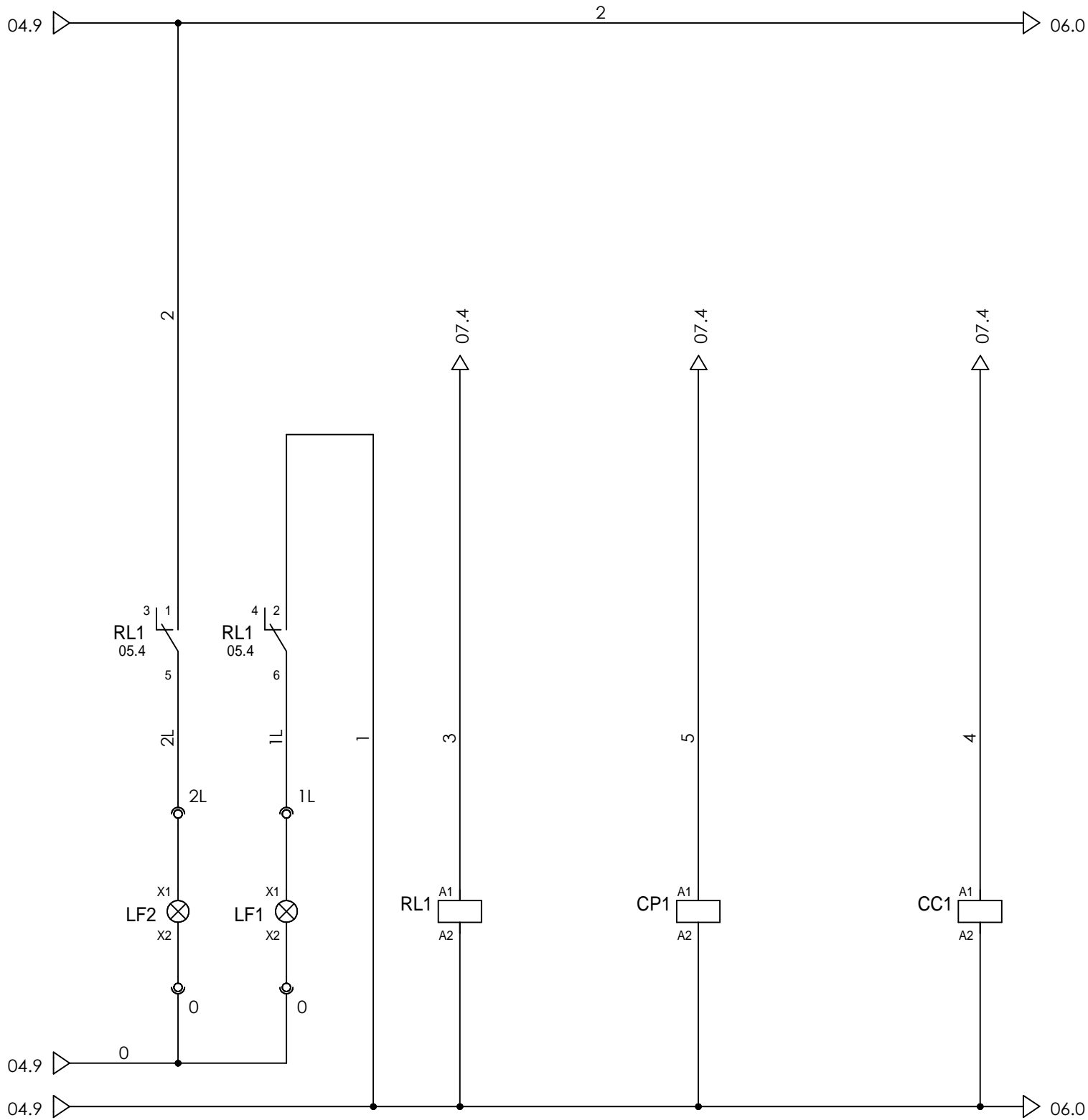

OVEN LIGHT

LIGHT RELAY

BEDPLATE HEATING ELEMENTS

CEILING HEATING ELEMENTS

05.9 2 07.0

05.9 1 07.0

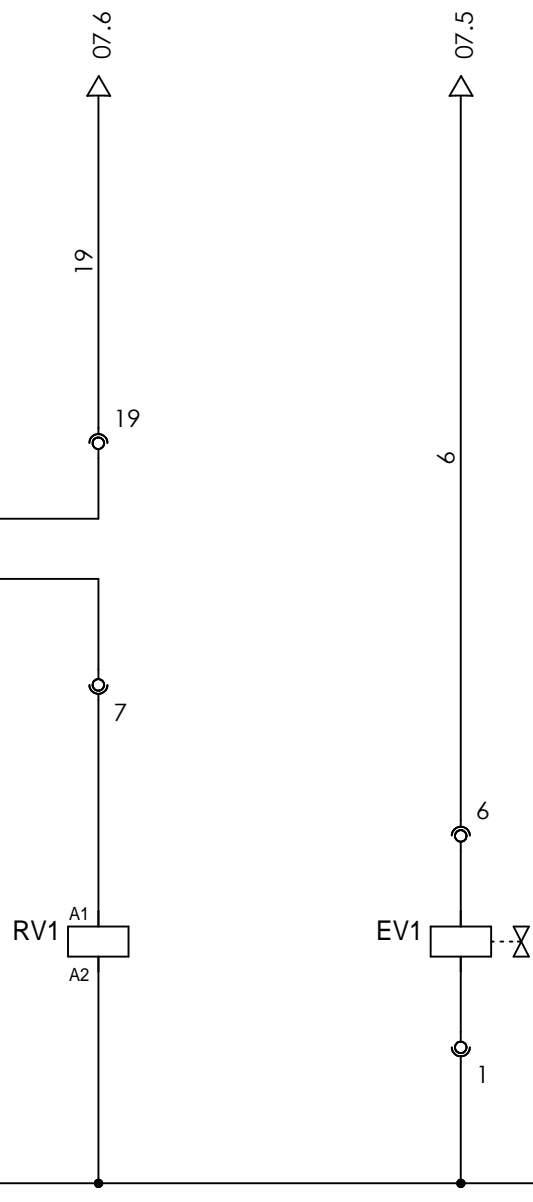
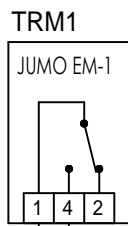

THERMOREGULATOR STEAM GENERATOR

STEAM SOLENOID VALVE

06.9  2

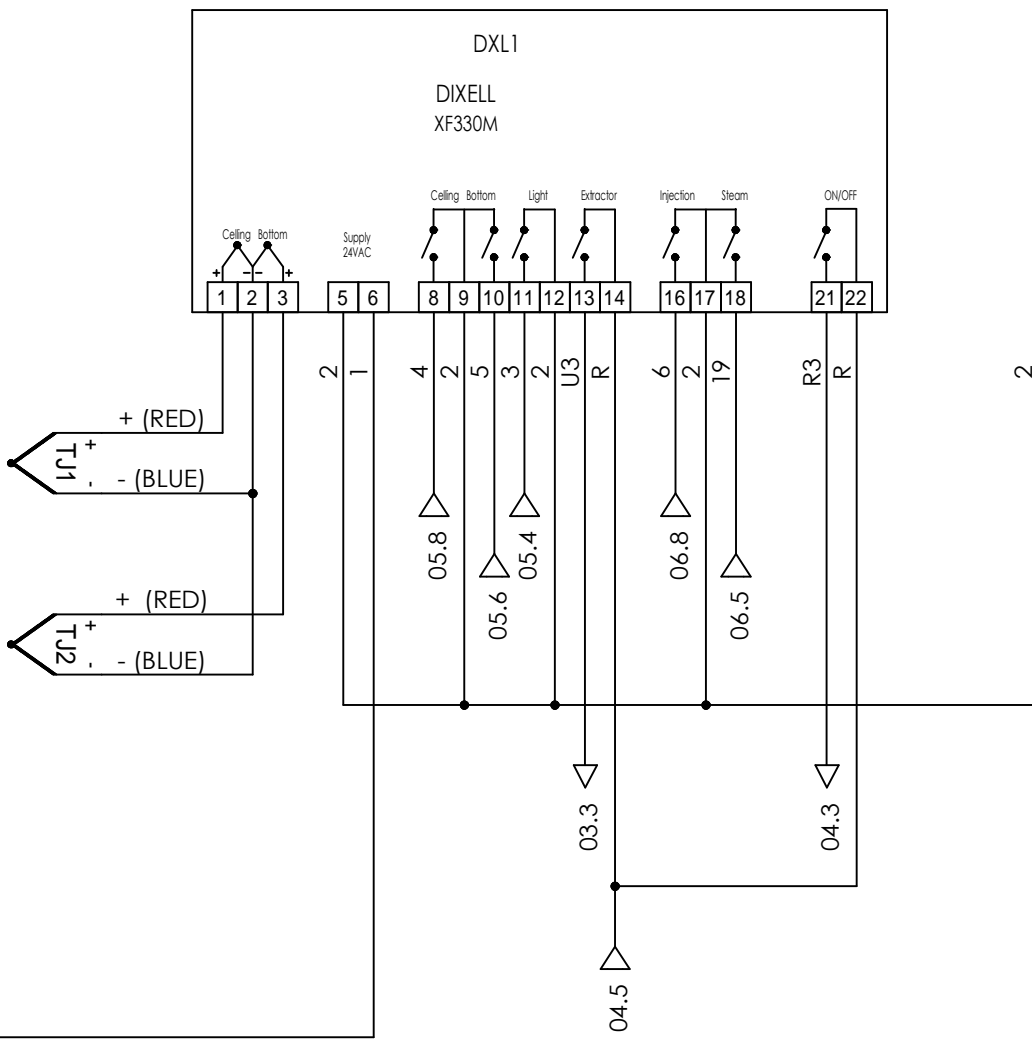

ELECTRONIC INSTRUMENT

USAGE SUMMARY

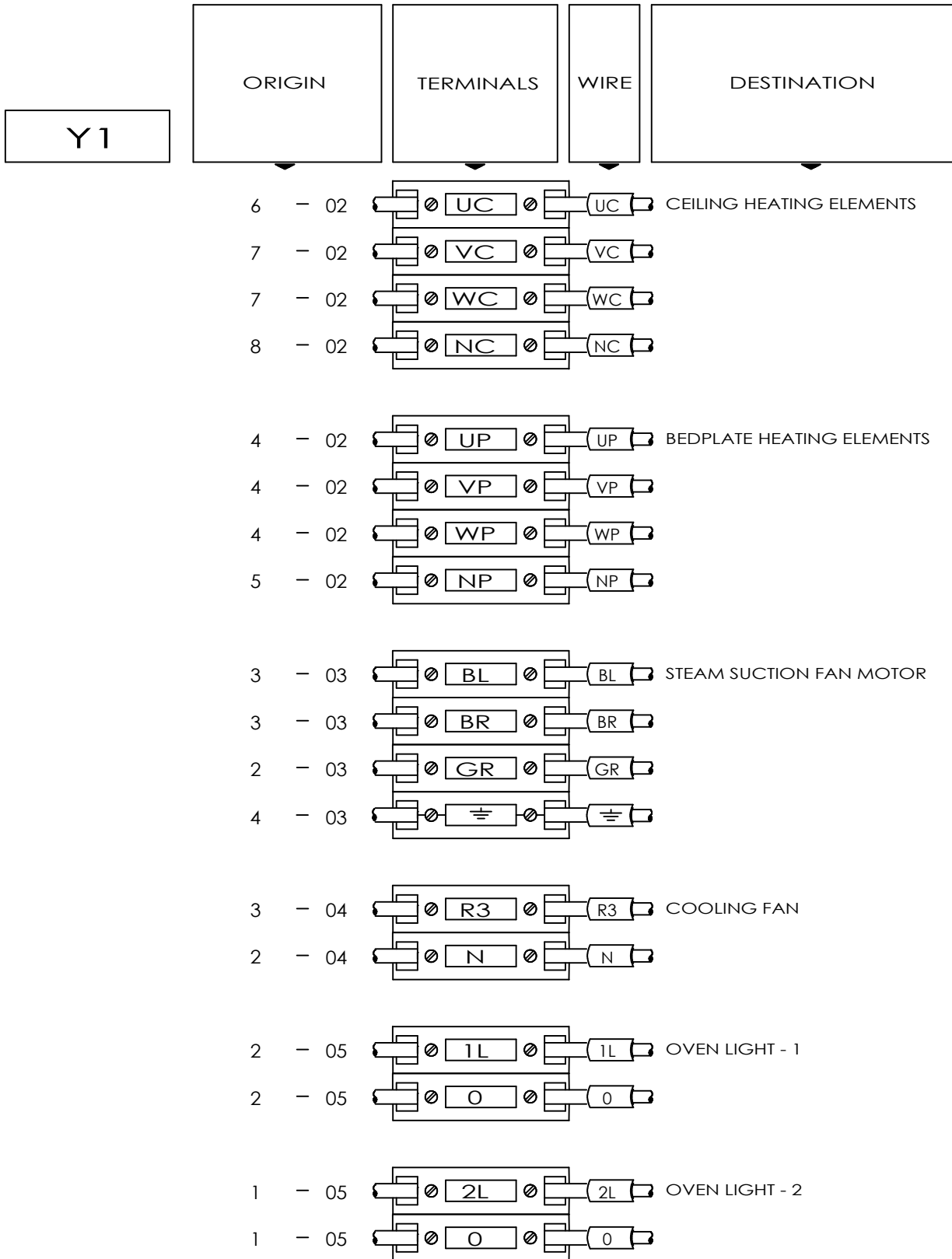

USAGE SUMMARY

	ORIGIN	TERMINALS	WIRE	DESTINATION
Y2				
	7 - 03	NV	NV	STEAM SET ELEMENT
	7 - 03	RV	RV	
	5 - 06	19	19	THERMOREGULATOR STEAM GENERATOR
	5 - 06	7	7	
	8 - 06	1	1	STEAM SOLENOID VALVE
	8 - 06	6	6	
	1 - 02	T	T	POWER SUPPLIER
	1 - 02	S	S	
	0 - 02	R	R	
	1 - 02	N	N	
	2 - 02	⊖	⊖	

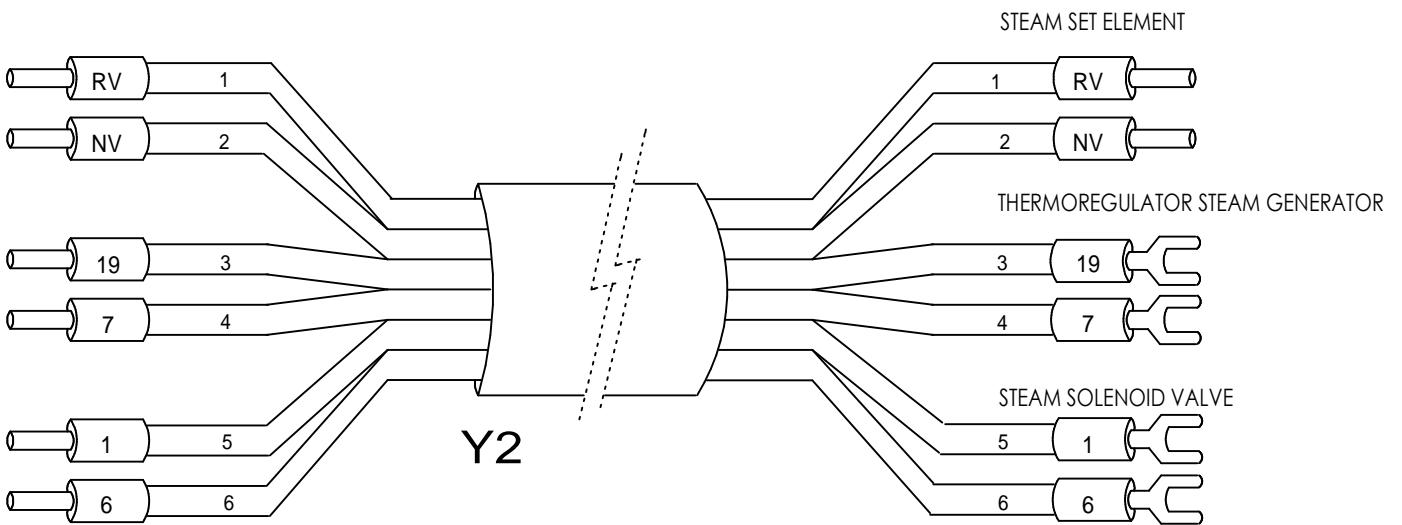

PARTS LIST

code	DESCRIPTION	SPARE PART	LOCATION	PAGE
CC1	CEILING HEATING ELEMENTS CONTACTOR	PRR 88	CP	05
CP1	BEDPLATE HEATING ELEMENTS CONTACTOR	PRR 88	CP	05
DXL1	ELECTRONIC INSTRUMENT	PRC 55/2	QC	07
E1	COOLING FAN	PRC 83/5	BM	04
EV1	STEAM SOLENOID VALVE	PRC 14 - PRC 15	BM	06
FC1	CEILING FUSES	PRC 46/9 - PRC 16/1	CP	02
FG1	MAIN FUSES	PRR 49 - PRR 27	CP	04
FP1	BEDPLATE FUSES	PRC 46/9 - PRC 16/1	CP	02
FV1	STEAM SET ELEMENT FUSES	PRR 49 - PRR 27	CP	03
LF1	OVEN LIGHT - 1	PRR 34/1	BM	05
LF2	OVEN LIGHT - 2	PRR 34/1	BM	05
M3	STEAM SUCTION FAN MOTOR	PRR 3/6	BM	03
RL1	LIGHT RELAY	PRR 61	CP	05
RST1	BEDPLATE HEATING ELEMENTS	PRC 15/4 - PRC 15/5	BM	02
RST2	CEILING HEATING ELEMENTS	PRC 15/4 - PRC 15/5	BM	02
RST3	STEAM SET ELEMENT	PRC 50	BM	03
RV1	STEAM SET ELEMENT RELAY	PRR 61	CP	06
TJ1	PROBE CEILING	PRR 72	CP	07
TJ2	PROBE BEDPLATE	PRR 72	CP	07

Power board

PRC 48/6

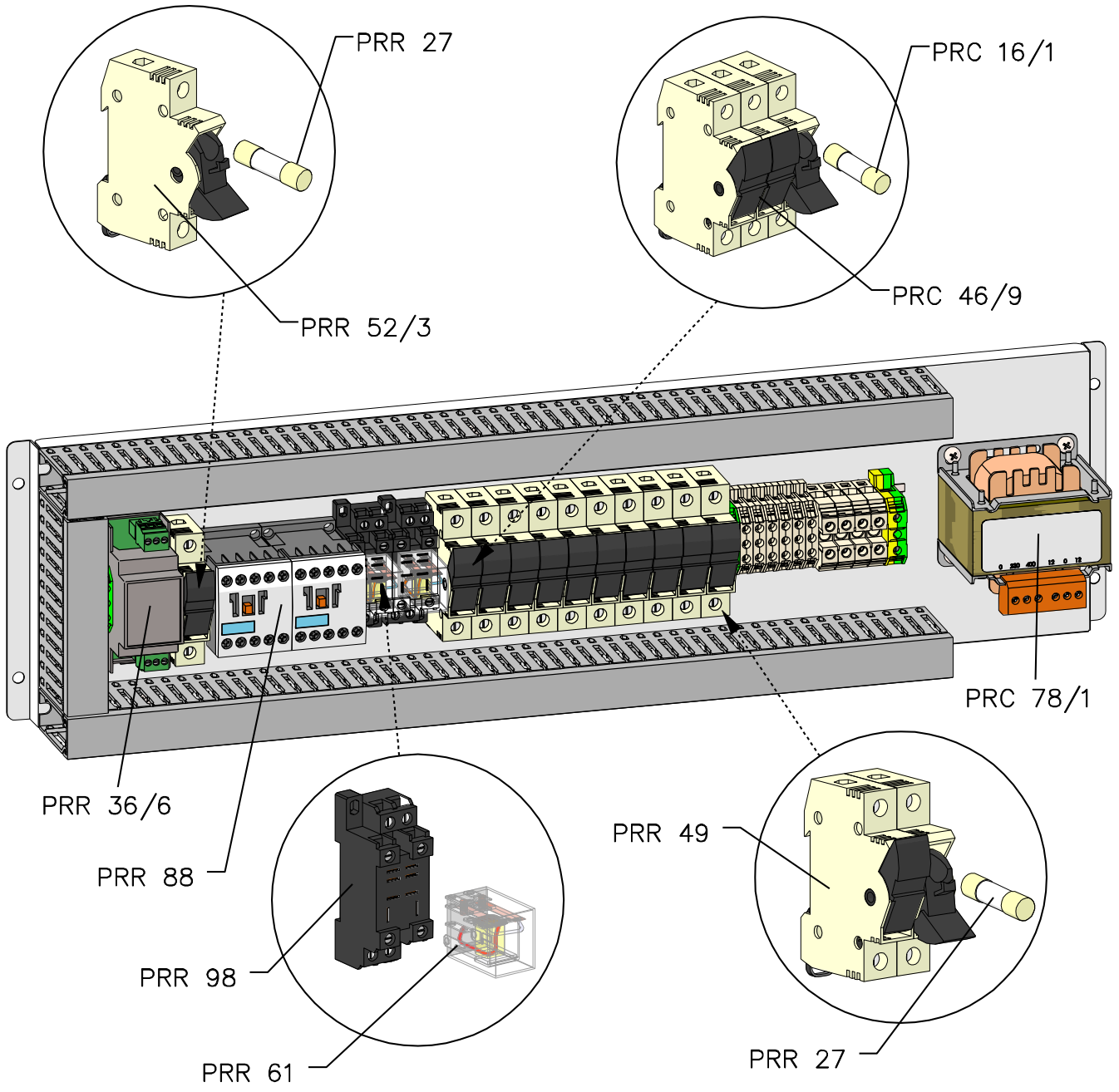

code

PRR 52/3	Standard fuse holder (single-polar)
PRR 27	Standard fuse
PRR 49	Standard fuse holderr (bipolar)
PRR 49	Standard fuse holderr (bipolar)
PRC 16/1	Fuse for electric deck oven
PRC 46/9	Fuse holder - tripolar - for electric deck oven
PRR 61	Relay
PRR 98	Base for relay
PRR 36/6	Interface For Steam Suction Fan - Single Phase
PRC 78/1	Transformer 100 VA
PRR 88	Normal remote-controlle switch

PRC 41/3

PRC 55/2

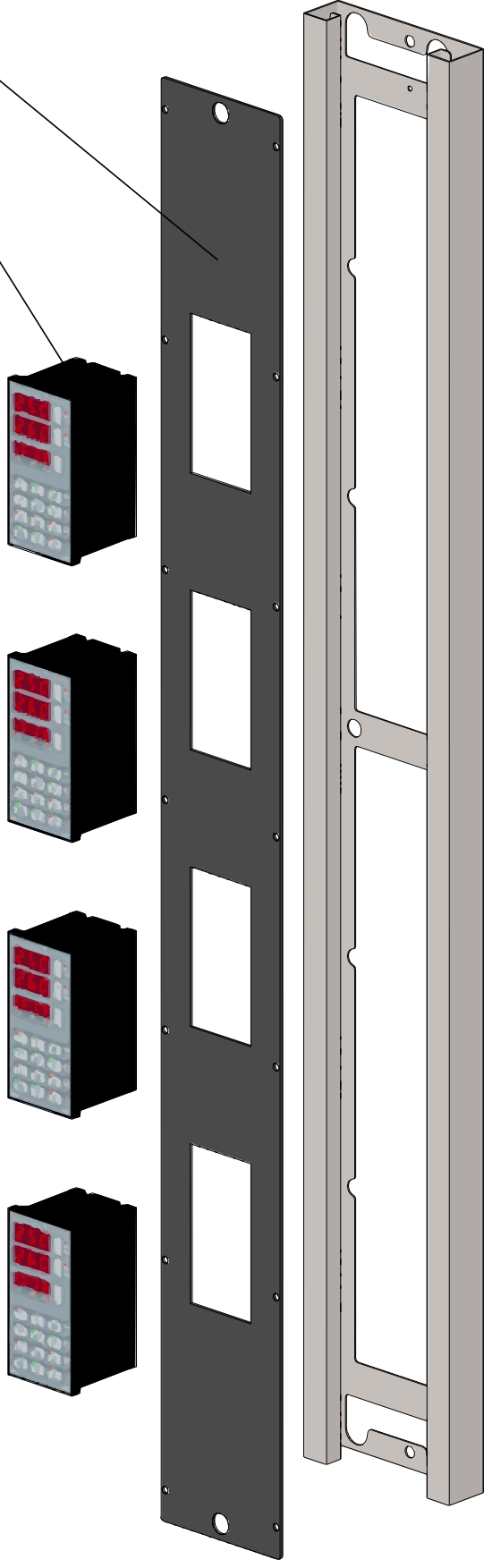

code

PRR 50/3	Screw With Black Knob
PRC 41/3	Instrument panel for oven modular
PRC 55/2	Electronic instrument DIXELL

