

SPARE PARTS LIST

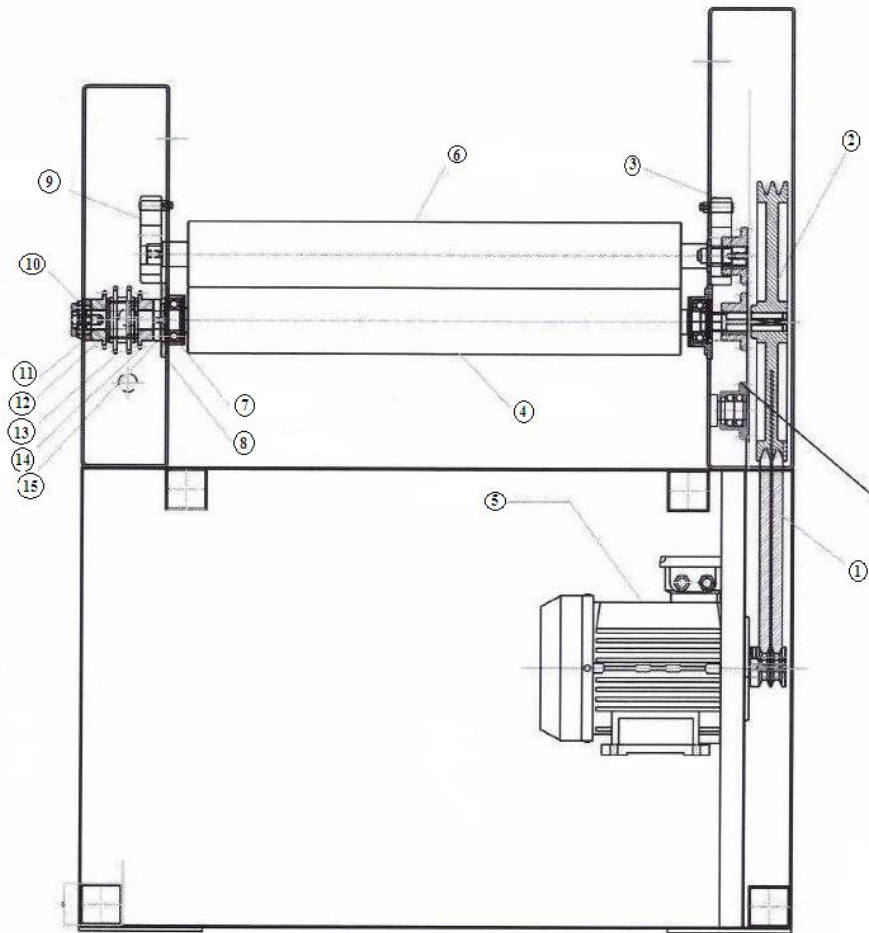

<u>POS.</u>	<u>CODE</u>	<u>DESCRIPTION</u>
1	ZTCS602136	BELT
2	ZTPS602037	PULLEY
3	ZLLS001018B	UPPER CYLINDER LEVER
4	ZSF650TC068	LOWER CYLINDER CALIBRATOR
5	ZSF650A088	MOTOR
6	ZSF650TC066	UPPER CYLINDER CALIBRATOR
7	ZTCS602130	BALL BEARING
8	ZTSS001080	LOWER CYLINDER
9	ZLLS001018B	UPPER CYLINDER LEVER
10	ZTRS001055	CLUTCH WASHER LID
11	ZTDS001082	REAR CLUTCH SPACER
12	ZTPS002094	CLUTCH PINION
13	ZTAS001097+ZTAS001098	PINION
14	ZTPS002094	CLUTCH PINION
15	ZTDS001052	FRONT CLUTCH SPACER

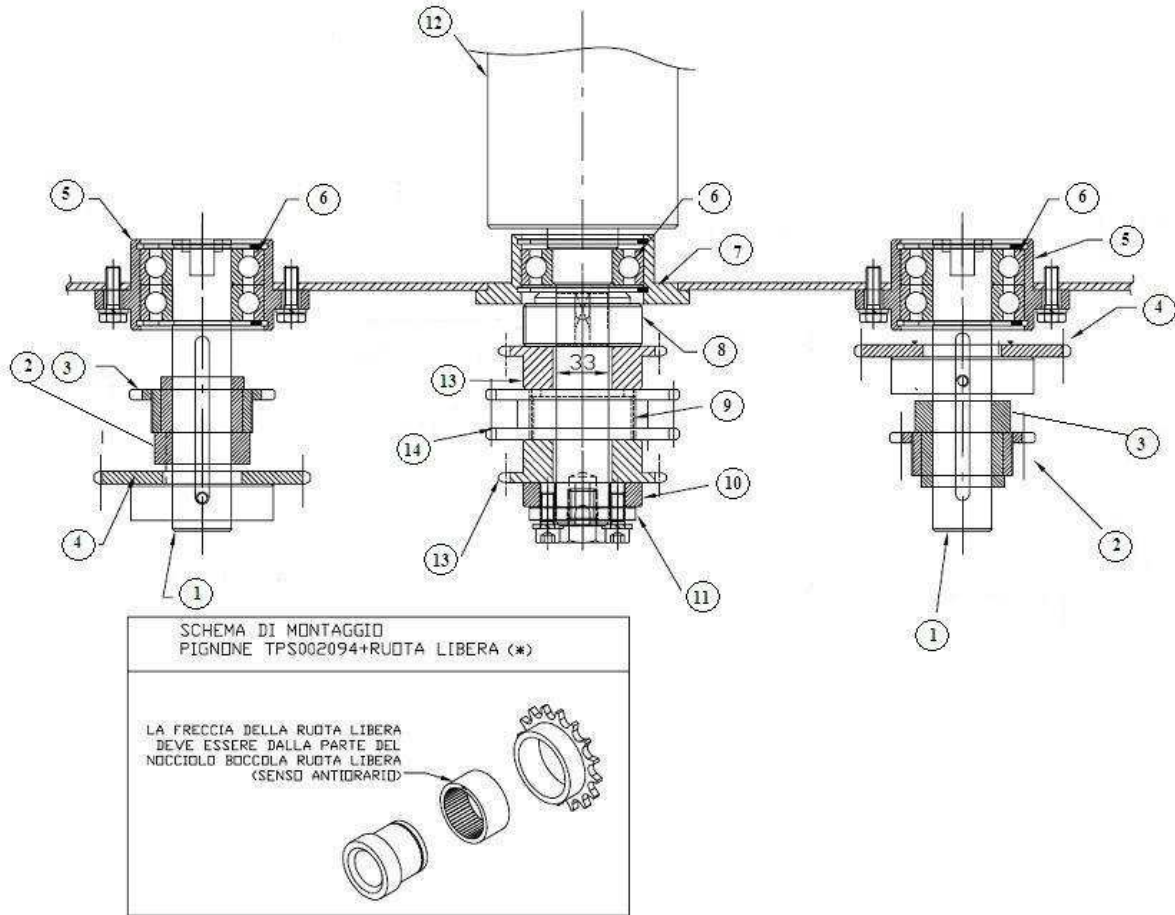

<u>POS.</u>	<u>CODE</u>	<u>DESCRIPTION</u>
1	ZTPS001062	PULL CYLINDER PIN
2	ZTPS002094A	PINION
3	ZTPS002096	FREEWHEEL
4	ZTPS002091	PINION
5	ZTSS001069	DRIVE SHAFT SUPPORT
6	ZTCS602130	BALL BEARING
7	ZTSS001080	SUPPORT
8	ZTDS001052	FRONT CLUTCH SPACER
9	ZTAS001098	THREADED ROD
10	ZTDS001082	REAR CLUTCH SPACER
11	ZTRS001055	CLUTCH WASHER LID
12	ZSF650TC068	LOWER CYLINDER CALIBRATOR
13	ZTPS002094	PINION
14	ZTAS001097	PINION

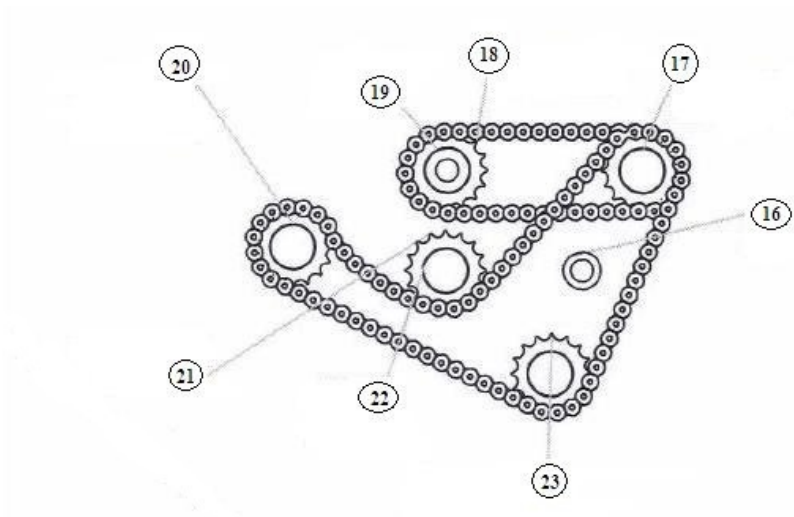

<u>POS.</u>	<u>CODE</u>	<u>DESCRIPTION</u>
16	ZTSS001073	SUPPORT
17	ZSF650A053	PINION
18	ZSF650A056	UPPER CYLINDER PINION SPACER
19	ZSF650TC066	UPPER CYLINDER CALIBRATOR
20	ZSF650A054	PINION
21	ZSF650A055	PINION
22	ZSF650TC068	LOWER CYLINDER CALIBRATOR
23	ZSF650A054	PINION

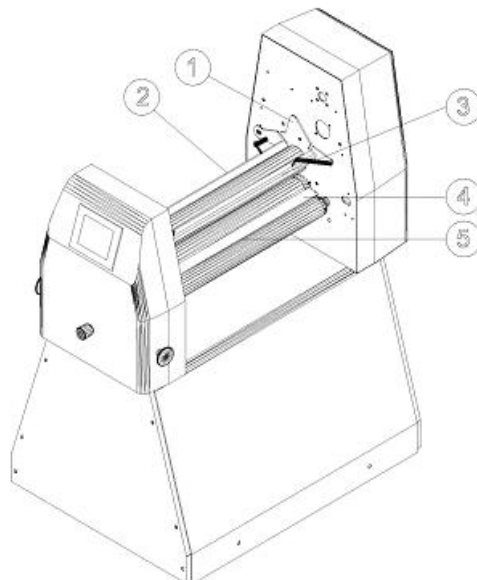

<u>POS.</u>	<u>CODE</u>	<u>DESCRIPTION</u>
1	SF650A039P	CLUMP FOR SCRAPER SUPPORT
2	SF650A039P	UPPER SCRAPER
3	ZTMS002165	SCRAPER SPRING
4	SF650A038P	LOWER SCRAPER
5	SF650A6720	DRIVING CYLINDER

AUTOMATIC FLOUR SPREADER

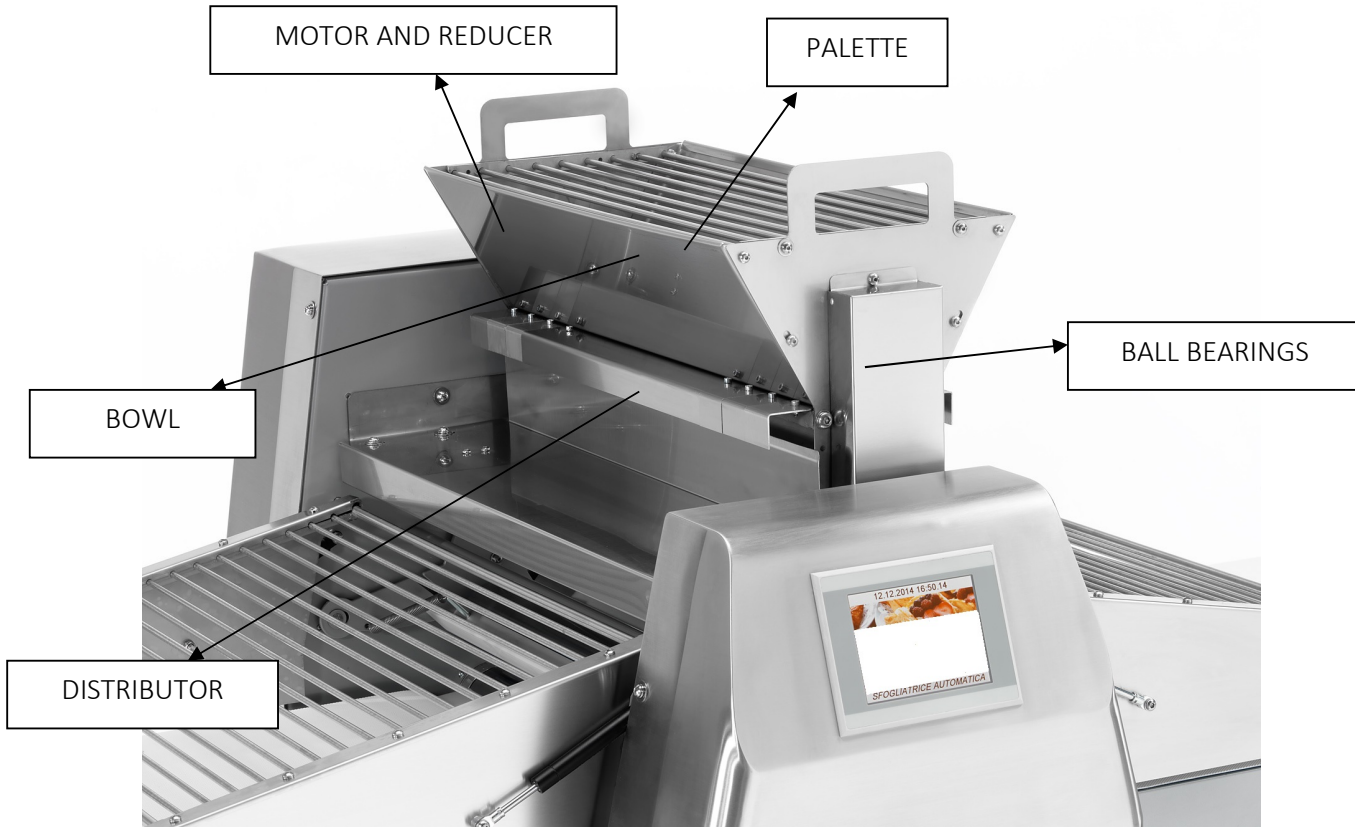

The working of the automatic flour spreader is programmable. Dusting of flour is manually adjustable in width and quantity with special drawers located in the same. With this system the flour consumption is considerably reduced and the quality of the product is better.

The object is composed of:

- stainless steel bowl
- palette for the descent of the flour
- distributor for dosing

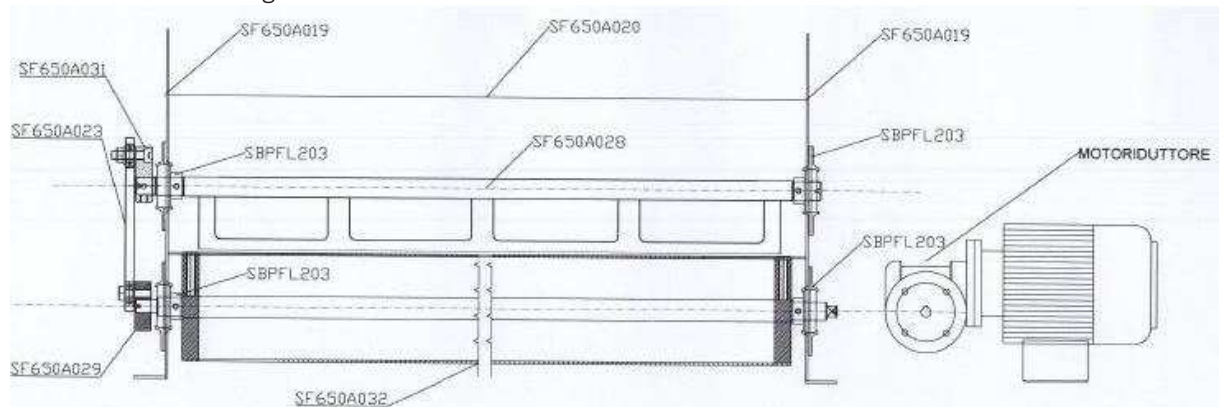

AUTOMATIC WINDER

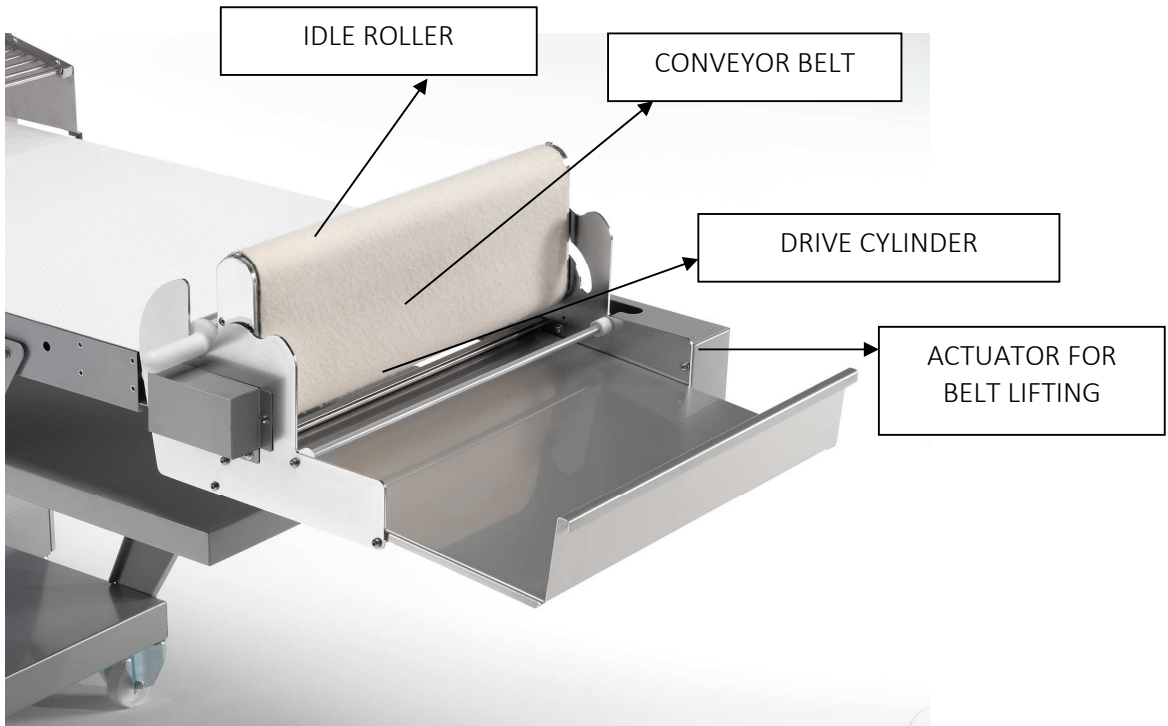

The winder is positioned at the end of the conveyor belt, to the right. This tool allows you to roll the dough gently when it reaches the desired thickness.

The winder is composed of:

- rolling pin
- actuator for the ascent and descent of the belt
- belt
- idle roller
- drive cylinder

