

Here below you have a representation of the equipment with a basis description of the main units and on the installed components.

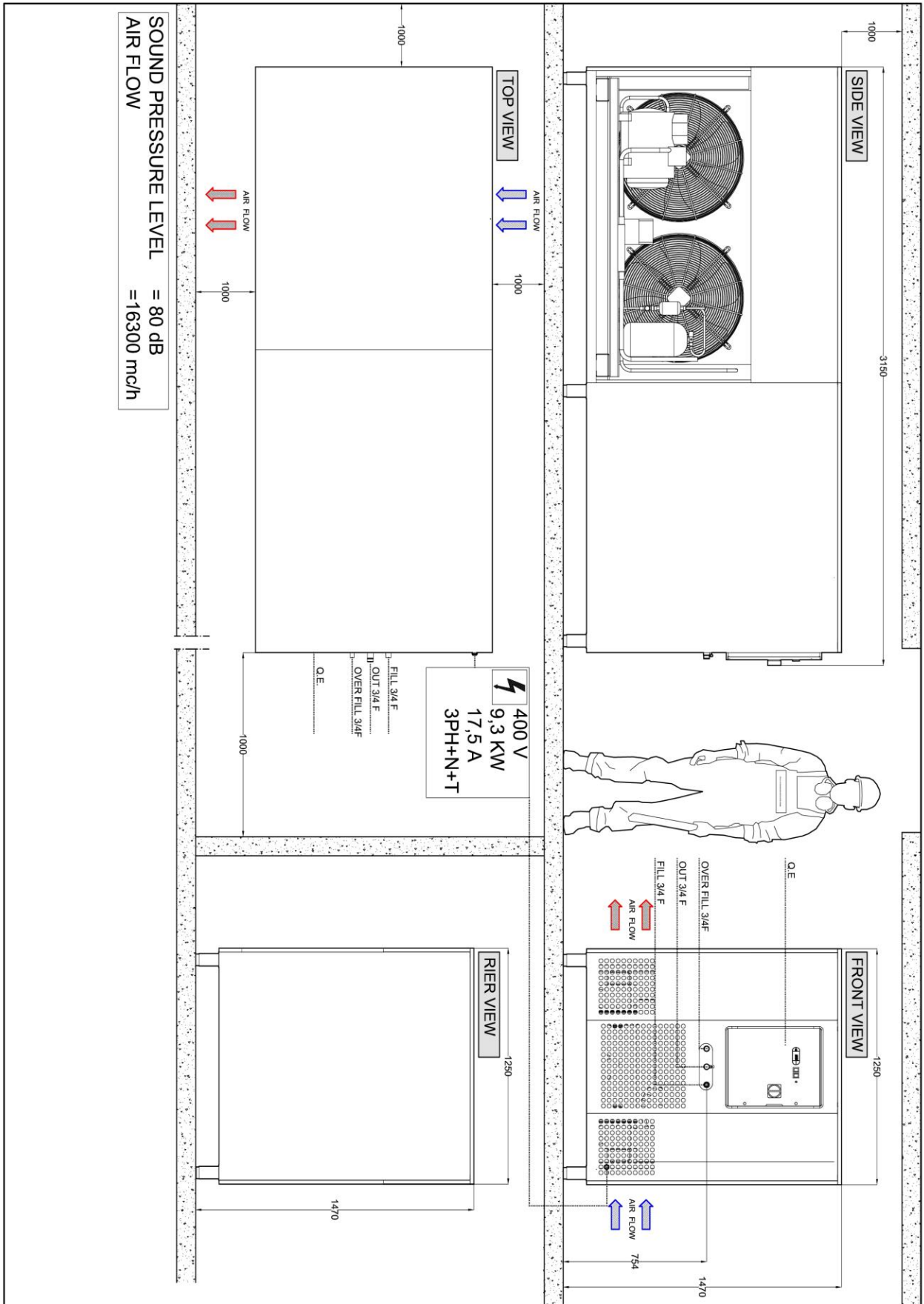

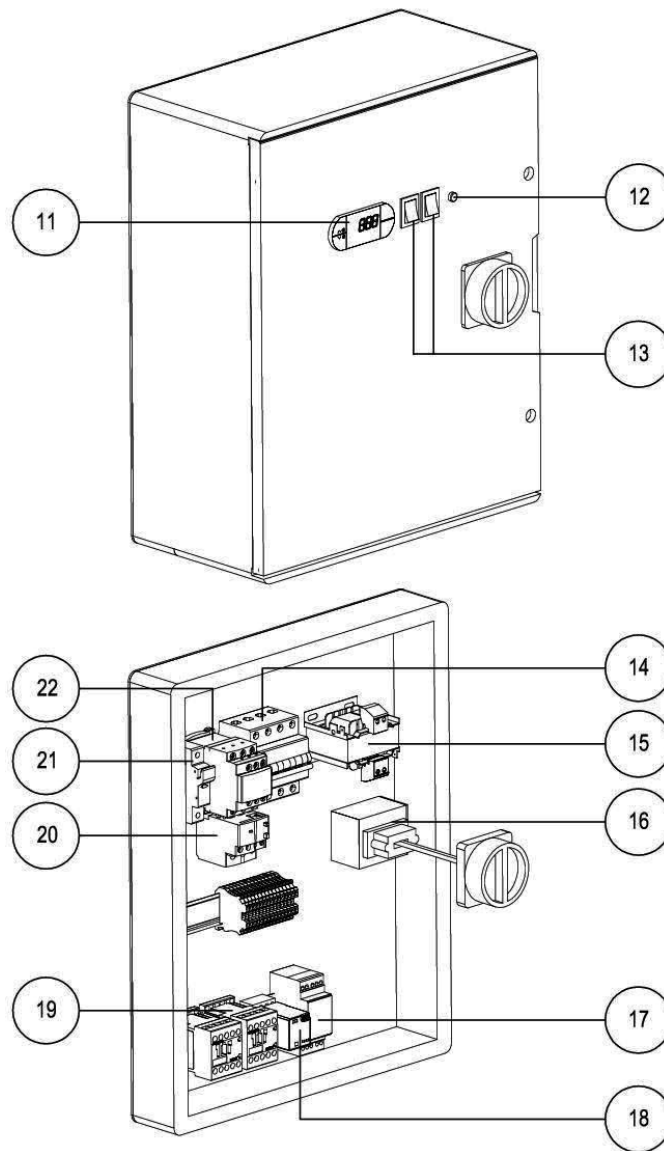

11	3600030543	THERMOSTAT
12	3600030476	SIGNAL LIGHT
13	8400010002	SWITCH
14	3500030272	SWITCH
15	3600030547	TRANSFORMER
16	3500030273	SWITCH
17	3600030441	LEVEL CONTROL RELAY
18	3600030440	RELAY
19	3600030040	CONTACTOR
20	3600030532	RELAY

21	3500030301	FUSE HOLDER
22	3600030035	CONTACTOR

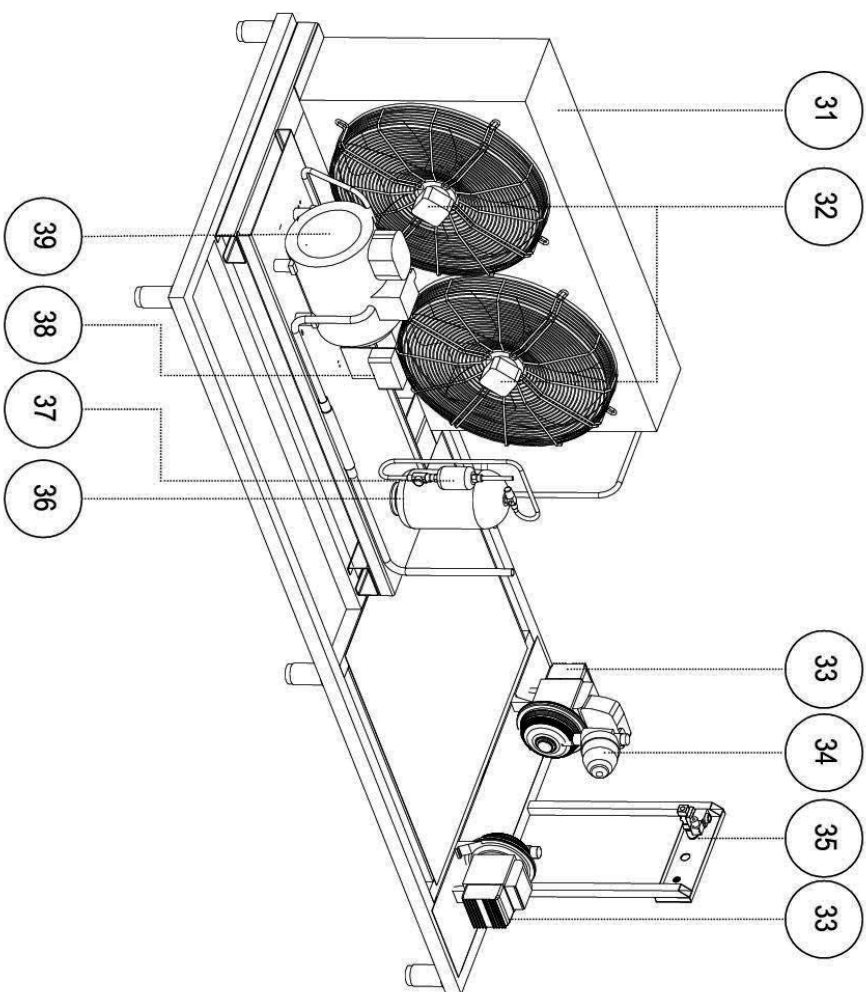

POS	COD	DESC
31		CONDENSER
32		FAN
33	2414000046	PUMP
34	2414000047	EASY PRESS
35	6700030023	WATER IN SOLENOID
36		LIQUID FREON TANK
37		FREON FILTER
38	2800003064	GAS PRESSURE SWITCH
39		COMPRESSOR

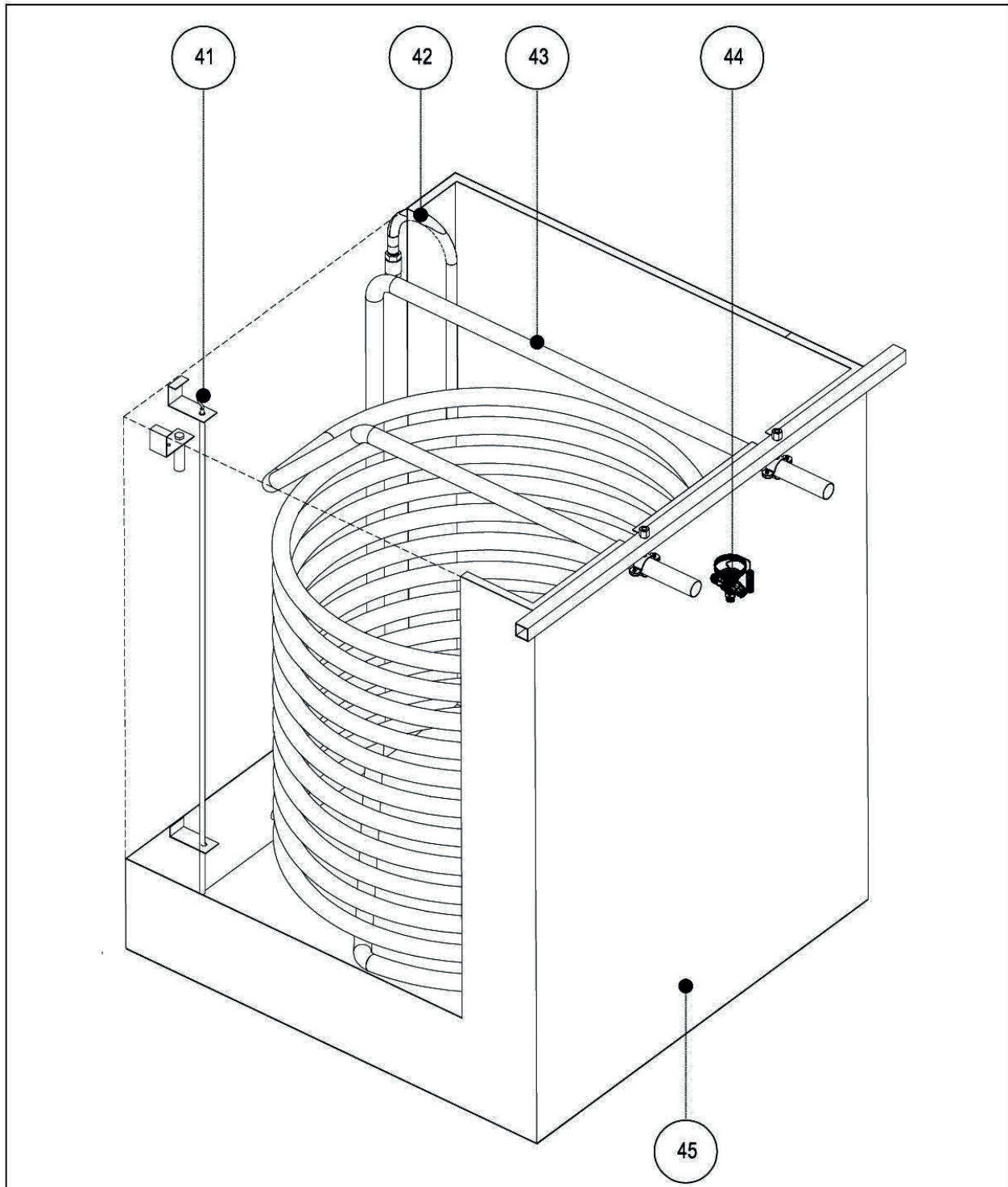

41	2800030415	PTC PROBE
42	CS000690040	FILL IN PIPE
43	CS00090084	EVAPORATOR
44	2800030050	THERM EXP. VALVE
45	CS00075081	TANK