

Here below you have a representation of the equipment with a basis description of the main units and on the installed components.

## Water chiller

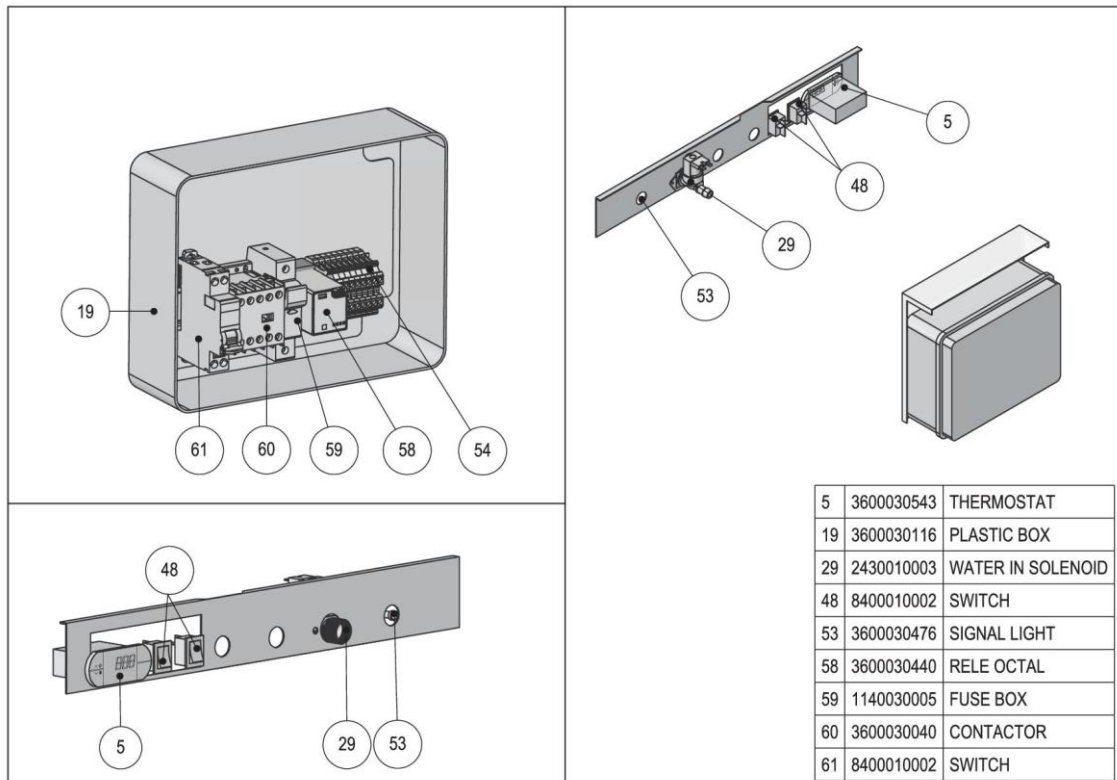

Refrigerating unit – Removed protections (Frontal inferior side)

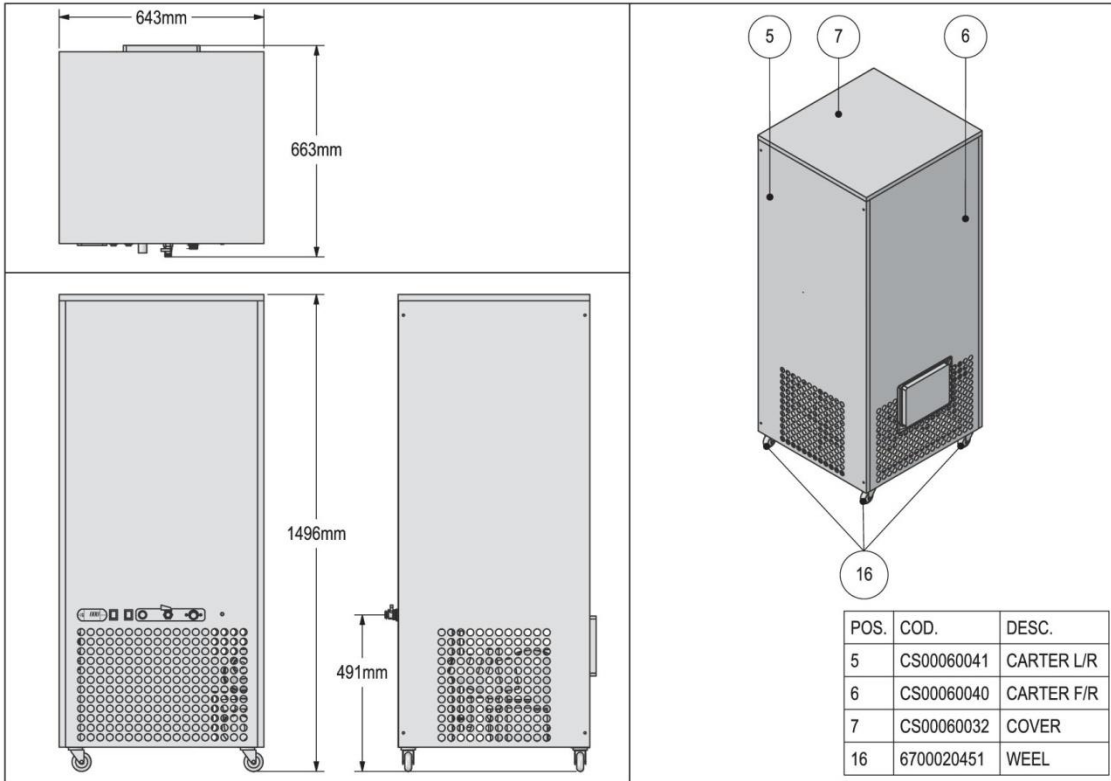
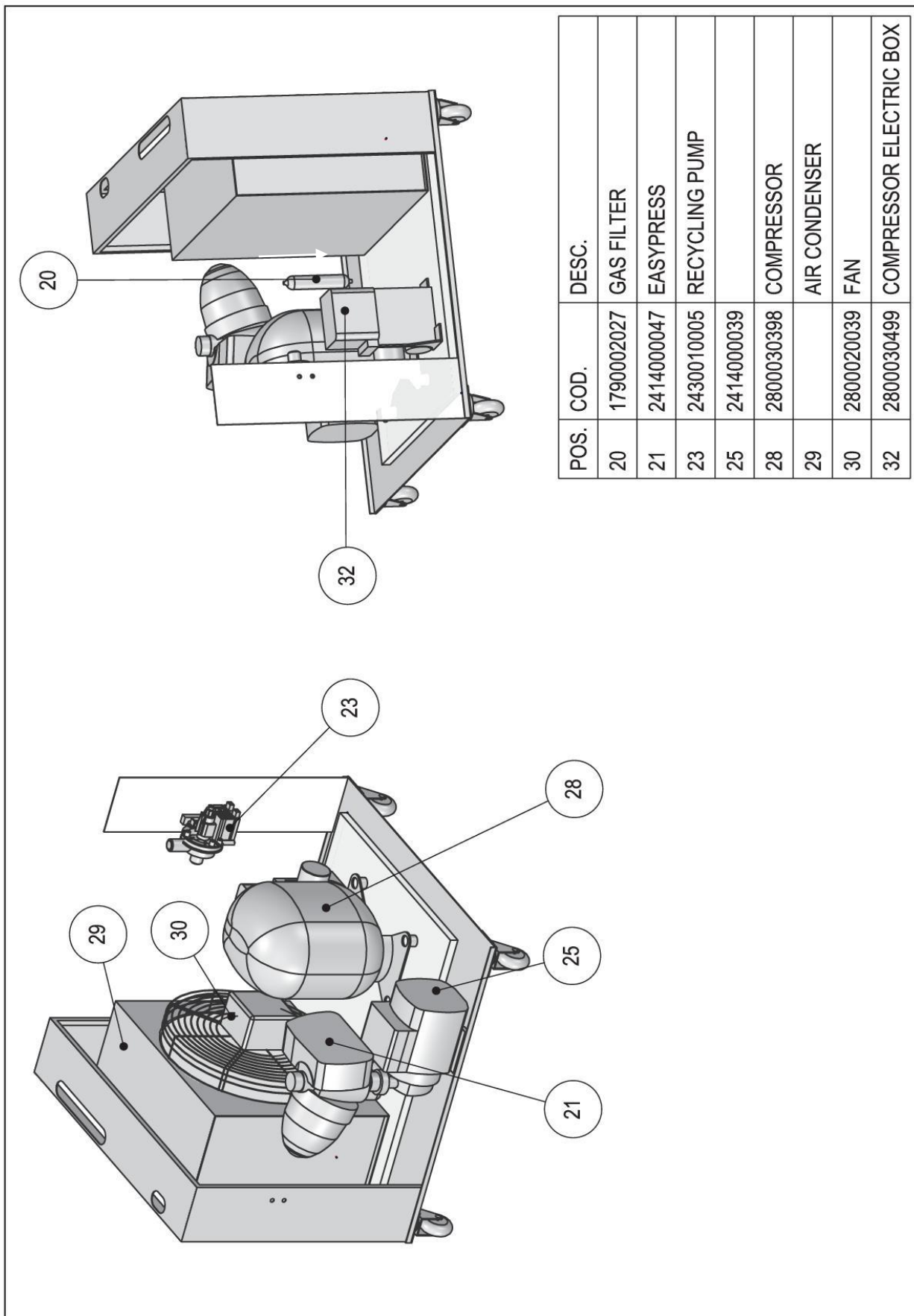

POS.	COD.	DESC.
20	1790002027	GAS FILTER
21	2414000047	EASYPRESS
23	2430010005	RECYCLING PUMP
25	2414000039	
28	2800030398	COMPRESSOR
29		AIR CONDENSER
30	2800020039	FAN
32	2800030499	COMPRESSOR ELECTRIC BOX

Water chiller – Removed protections (upper side)

