

WIRING DIAGRAM

Progetto: MSP40-60 TIMER SITEC DOPPIO MAC PAN Cliente: Disegnatore: Data:	Tensione esercizio:	220-400V
	Tensione ausiliari:	24 VAC
	Frequenza:	50-60 Hz
	Corrente nominale:	
	Potenza totale:	
	Grado di protezione:	

WIRING DIAGRAM

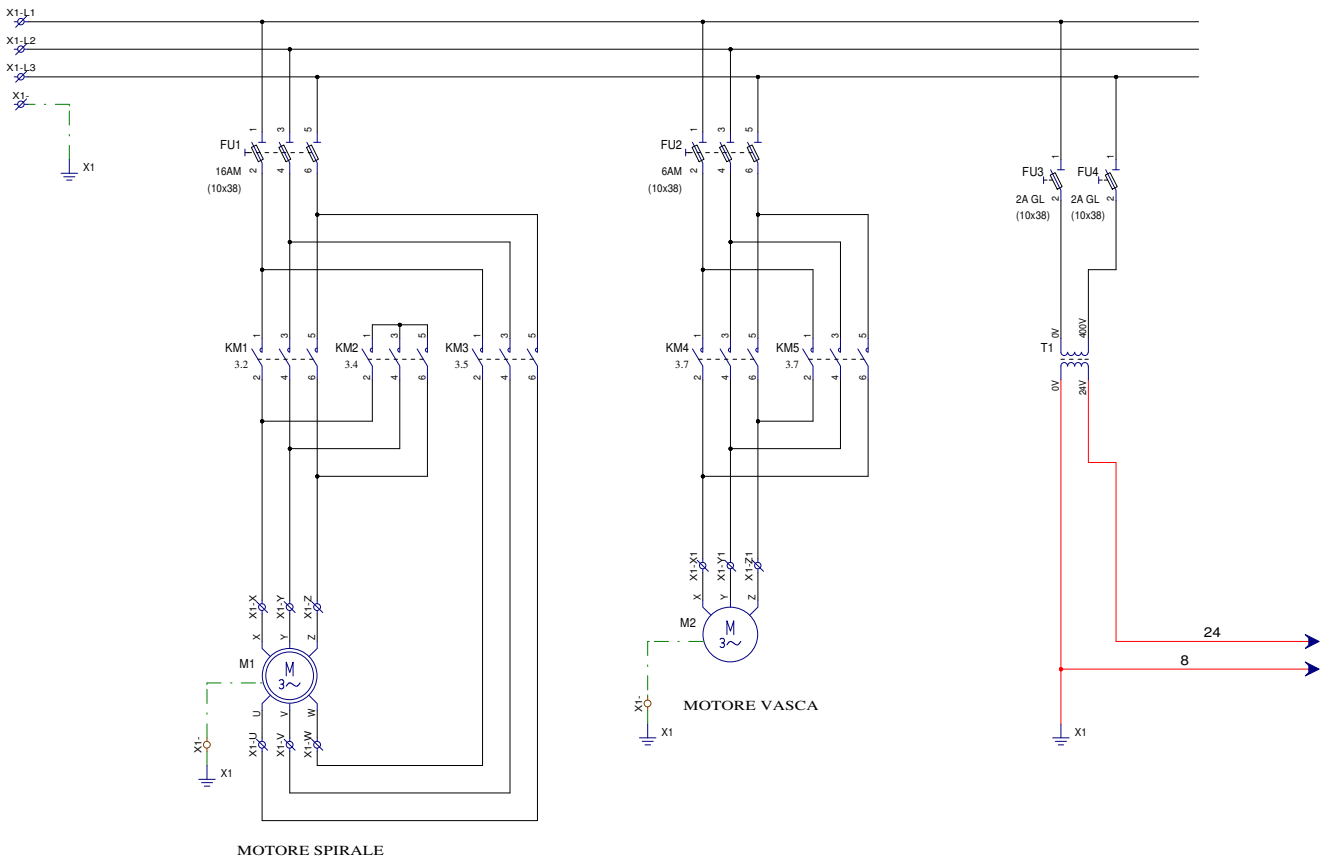

MADE IN ITALY

WIRING DIAGRAM

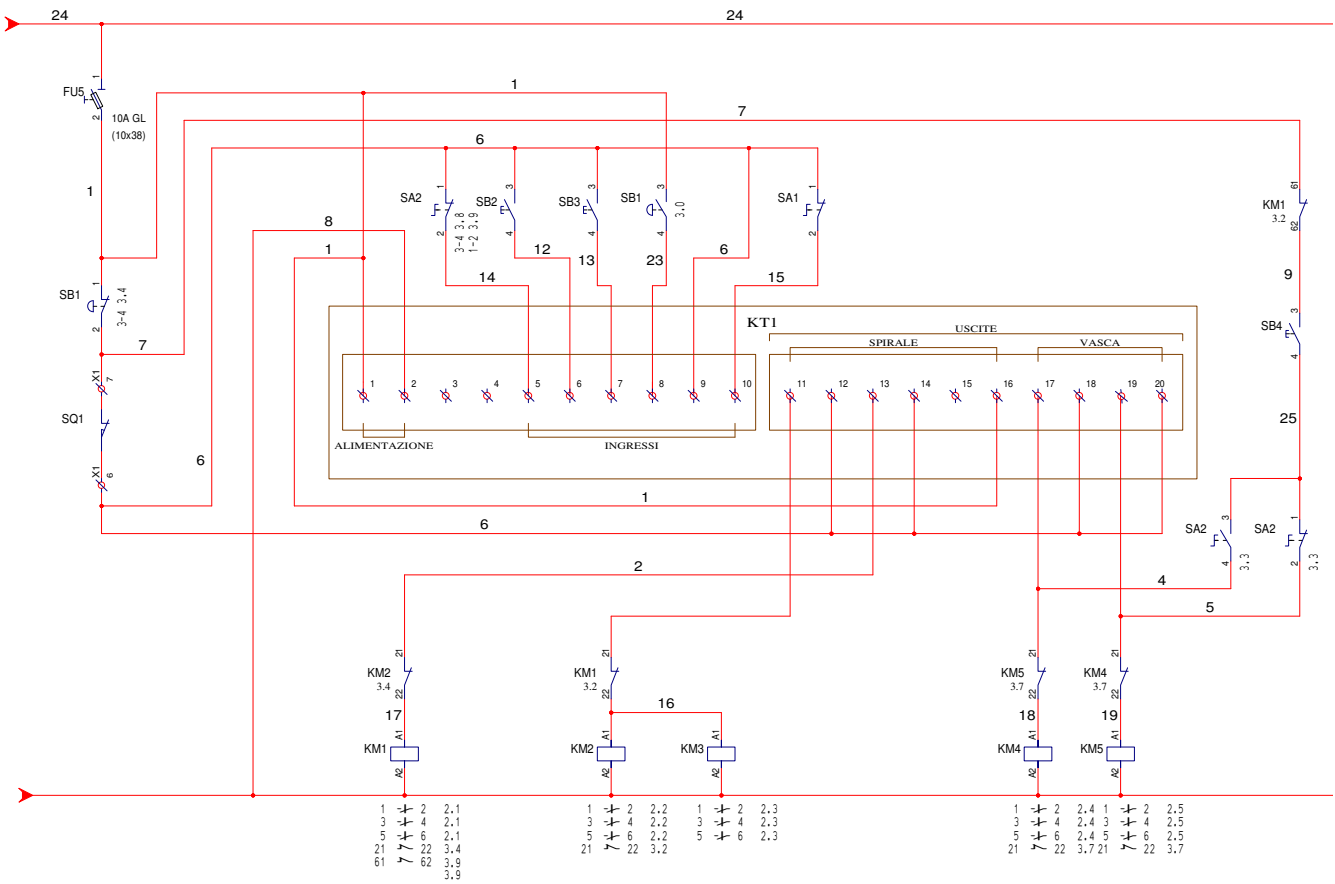

MADE IN ITALY

WIRING DIAGRAM

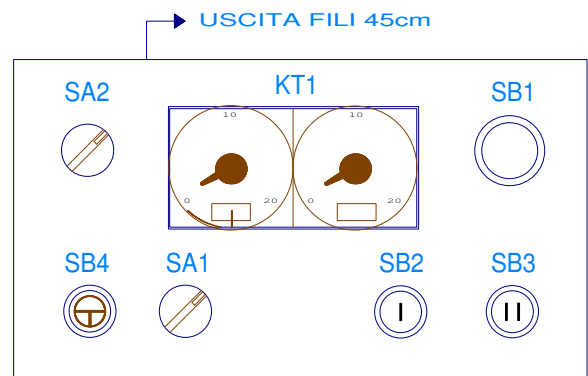
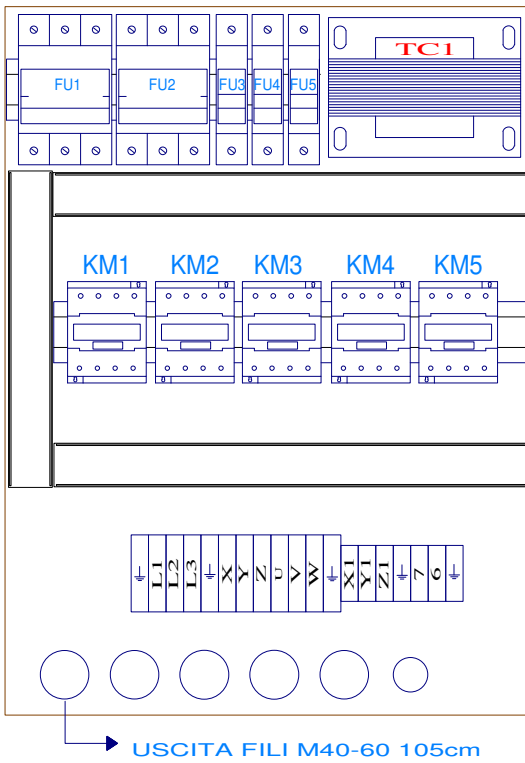

MADE IN ITALY

WIRING DIAGRAM

Progetto: MSP80-250 TIMER SITEC DOPPIO MAC PAN Cliente: Disegnatore: Data:	Tensione esercizio:	220-400V
	Tensione ausiliari:	24 VAC
	Frequenza:	50-60 Hz
	Corrente nominale:	
	Potenza totale:	
	Grado di protezione:	

WIRING DIAGRAM

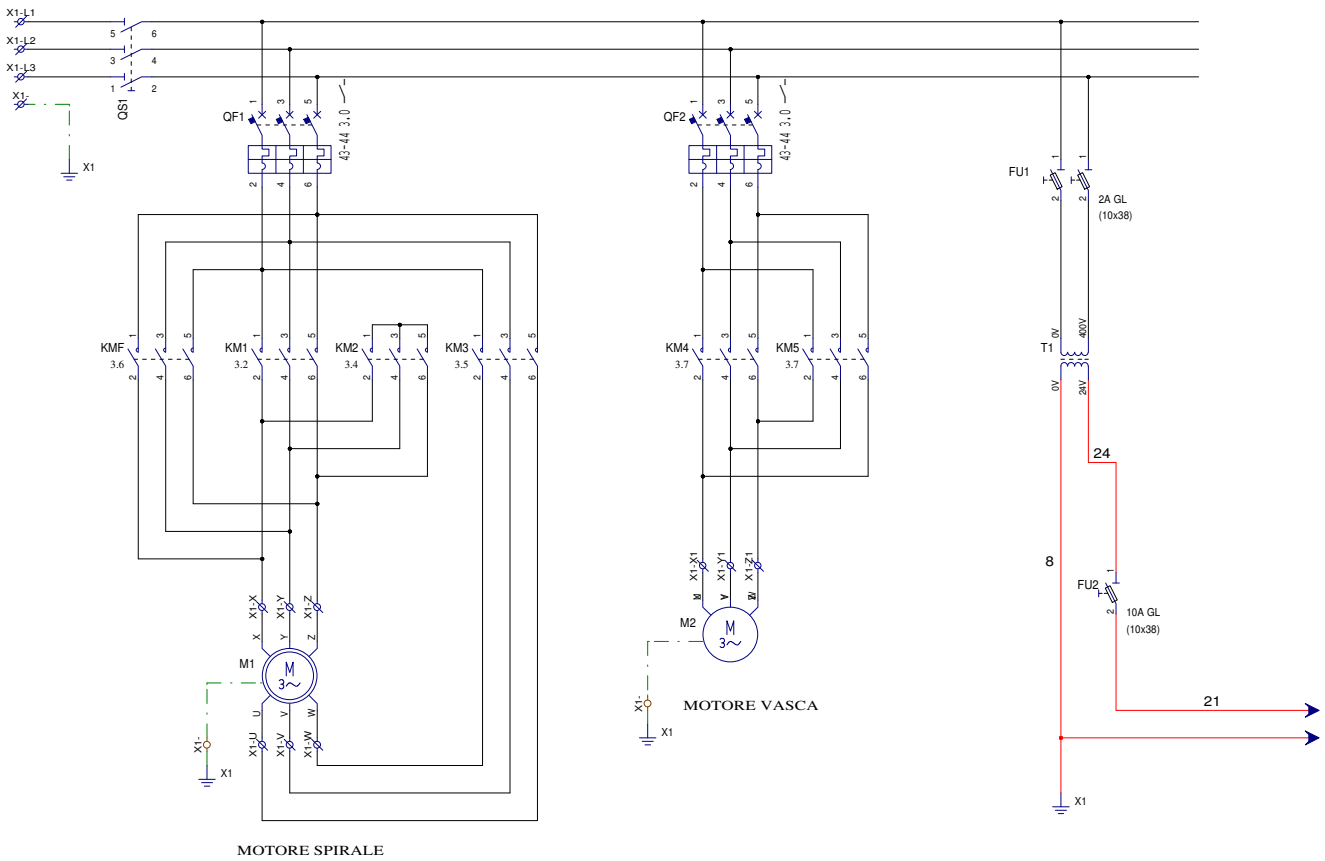

MADE IN ITALY

WIRING DIAGRAM

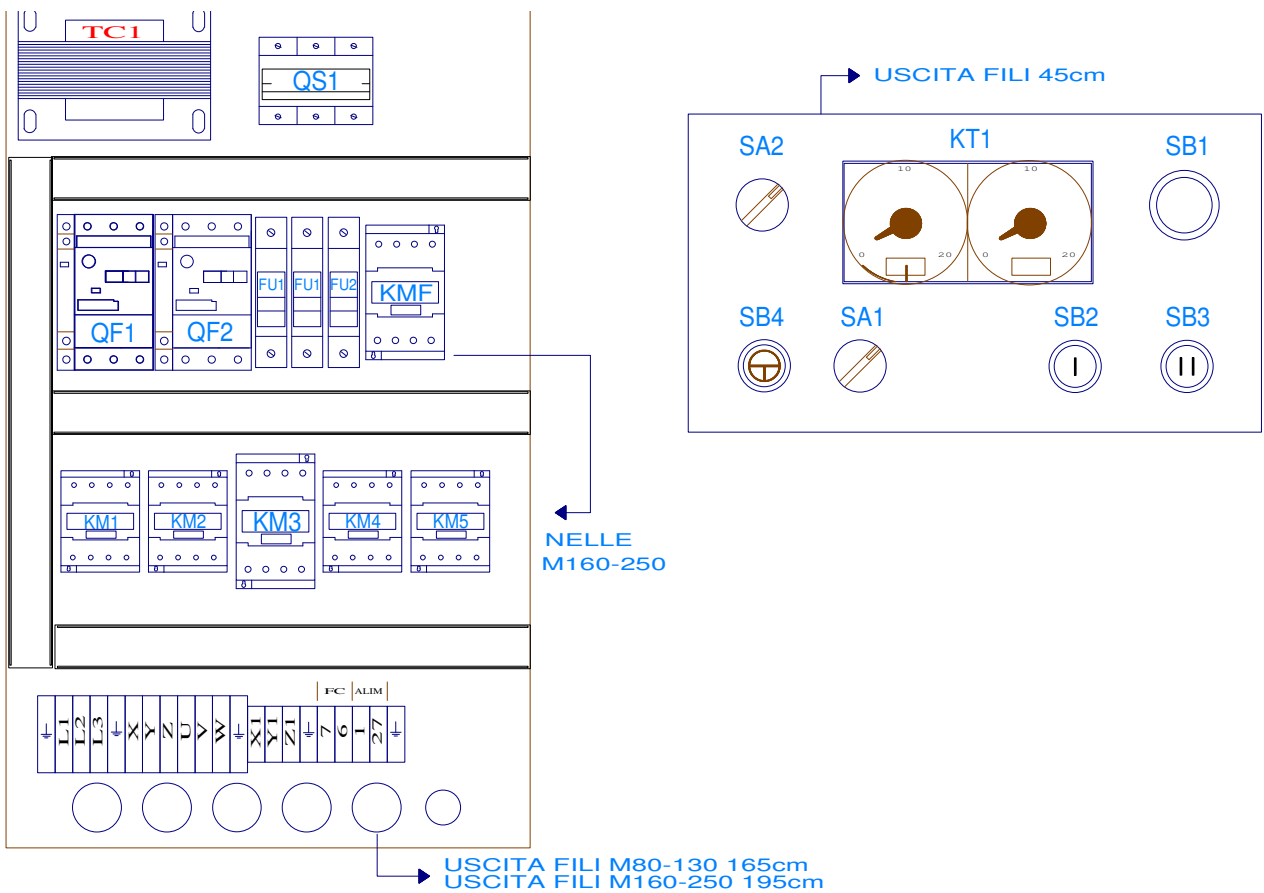

MADE IN ITALY